

Unipi Axon S155

PRODUCT DESCRIPTION

Unipi Axon S155 is a programmable logic controller (PLC) and gateway designed for automation, control, regulation and monitoring. The S155 is a compact model with a universal architecture combining digital and analog I/Os suitable for simple installations. A special feature of the S155 is a pair of Ethernet ports that allows the controller to be used as a hub between two networks, or to act as a network switch. The S155 also features three serial interfaces (RS485+RS232) for connection of extension modules or gateways and a 1-Wire interface for connection of digital temperature or humidity sensors.

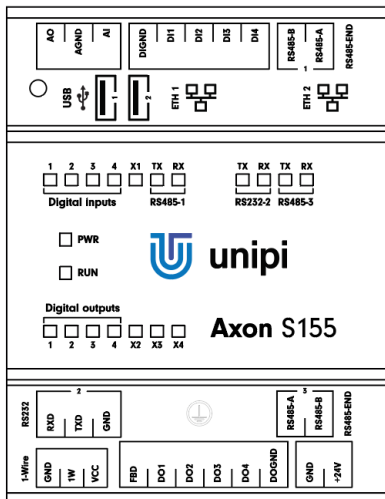

COMPUTING MODULE

Allwinner H5 1.2 GHz quad-core CPU, 1GB RAM, 8GB eMMC onboard memory

FEATURES

Inputs/outputs

- 4 × digital input incl. counter
- 4 × digital output
- 1 × analog input
- 1 × analog output

Software

- Powered by OS Linux
- Mervis – IDE (IEC 61131-3), HMI editor, proxy server, cloud database, SCADA, wide range of supported protocols
- Open-source solutions – Node-RED, openHAB, Homebridge, FHEM, PiDome, DomotiGa, Domoticz, Pimatic and many more
- Custom SW implementation– EVOK open API, Modbus TCP interface, SysFS

FUNCTIONALITY

Automation, IoT and IIoT, remote online monitoring and regulation, HVAC control, SCADA, sensorics, smart home control (lighting, doors, locks, irrigation etc.)

Communication interfaces

- 2 × RS485
- 1 × RS232
- 1 × 1-Wire bus
- 1 × 1Gbit Ethernet
- 1 × 10/100Mbit Ethernet
- 2 × USB 2.0

Other features

- Built-in webserver
- Special functions – Direct Switch, MasterWatchdog, user LEDs
- Durable aluminium chassis (IP20)
- Extended operating temperature range
- Available in an OEM variant
- Custom development available (IQRf, LoRa, wM-Bus, ZigBee, EnOcean and more)

Unipi Axon S155

• Communication

| | |
|-----------------------------------|---|
| Ethernet | 1 × 1Gbit Ethernet 1 × 10/100Mbit Ethernet |
| Serial/bus channels | 2 × RS485, 1 × RS232, 1 × 1-Wire |
| RS485 1 transmission speed | 134 baud .. 115 200 baud |
| RS485 3 transmission speed | 50 baud .. 3 Mbaud |
| RS485 galvanic isolation | Yes |
| RS485 biasing resistors | Yes, 560 Ω |
| RS485 terminating resistor | Built-in attachable, 120 Ω |
| RS232 transmission speed | 50 baud .. 3 Mbaud |
| RS232 galvanic isolation | No |
| 1-Wire galvanic isolation | Yes |
| 1-Wire output voltage Vcc | 5 V |
| 1-Wire max. current Vcc | 50 mA |
| 1-Wire connector | 3 × pole, max. 1.5 mm ² |
| WiFi | IEEE 802.11 b/g/n |
| Bluetooth | 4.0, Low Energy (BLE) |
| WiFi/Bluetooth antenna | Internal |
| USB | 2 × USB 2.0 |

• Digital inputs

| | |
|---|---|
| Nr.of inputs × groups | 4 × 1 |
| Common connector | DIGND |
| Galvanic isolation | Yes |
| Functions of inputs | Counter (incl. memory), signalization, Direct Switch |
| Max. frequency of counter input signal | 10 kHz |
| Input voltage of log. 0 | Max. 3 V DC |
| Input voltage of log. 1 | Min. 7 V DC |
| Max. input voltage | 35 V DC |
| Input resistance | 6 200 Ω |
| Delay 0→1/1→0 | 20 μs / 60 μs |

• Digital outputs

| | |
|---|---------------------------------|
| Nr.of outputs × groups | 4 × 1 |
| Common connector | DOGND |
| Galvanic isolation | No |
| Type of output | NPN transistor (open collector) |
| Optional functions | PWM |
| Switchable voltage | 5-50 V DC |
| Switchable current continual/pulse | 750 mA / 1 A |
| Max. total current DO1 – DO4 | 1 A |
| PWM max. frequency | 200 kHz |
| PWM max. resolution | 16 bits |

• Analog inputs

| | |
|--------------------------------------|------------------------|
| Nr.of inputs × groups | 1 × 1 |
| Common connector | AGND |
| Available functions | 0-10 V 0-20 mA |
| Galvanic isolation | No |
| Resolution | 12 bits |
| Conversion speed | 10 μs |
| Input resistance | 66 kΩ – U 100 Ω – I |
| Resistance measurement method | – |

• Analog outputs

| | |
|--------------------------------------|--|
| Nr.of outputs × groups | 1 × 1 |
| Common connector | AGND |
| Available functions | AO 0-10 V / 0-20mA Resistance measurement: 0-2 kΩ (Pt/Ni1000) |
| Galvanic isolation | No |
| Max. voltage/current | 10 V / 20 mA |
| Resolution | 12 bits |
| Conversion speed | 1 ms |
| Resistance measurement method | 2wire |

• Power supply

| | |
|------------------------------------|-----------------------|
| Rated voltage - SELV | 24 V DC |
| Power consumption | Typ. 3 W Max. 12 W |
| Reverse polarity protection | Yes |

• Installation and operating conditions

| | |
|--|---|
| Operating conditions | 0 °C .. + 70 °C, relative humidity 10 % .. 95 %, without aggressive substances, condensing vapor and fog |
| Storing conditions | - 25 °C .. + 70 °C, relative humidity 10 % .. 95 %, without aggressive substances, condensing vapor and fog |
| Degree of protection IP (IEC 529) | IP 20 |
| Operation position | Horizontal |
| Installation | On 35mm DIN rail into distribution box (holder included) |
| Connection | Pluggable terminal blocks |
| Wire gauge | Max. 2.5 mm ² |

• Dimensions and weight

| | |
|-------------------|-----------------|
| Dimensions | 70 × 90 × 60 mm |
| Weight | 210 g |

• Standards compliance

| |
|-----------------------------|
| EN 60730-1 ed.3:2012 |
| RoHS |
| WEEE |