

# Unipi Axon S155

## PRODUCT DESCRIPTION

Unipi Axon S155 is a programmable logic controller (PLC) and gateway designed for automation, control, regulation and monitoring. The S155 is a compact model with a universal architecture combining digital and analog I/Os suitable for simple installations. A special feature of the S155 is a pair of Ethernet ports that allows the controller to be used as a hub between two networks, or to act as a network switch. The S155 also features three serial interfaces (RS485+RS232) for connection of extension modules or gateways and a 1-Wire interface for connection of digital temperature or humidity sensors.

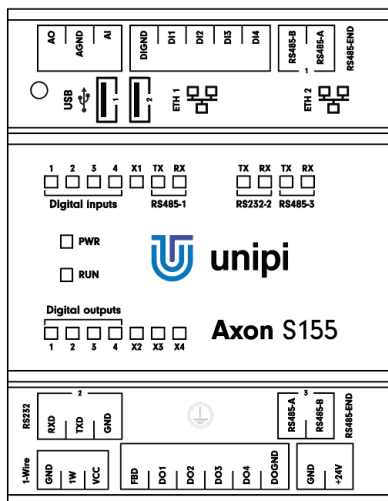

## COMPUTING MODULE

Allwinner H5 1.2 GHz quad-core CPU, 1GB RAM, 8GB eMMC onboard memory

## FEATURES

Inputs/outputs

- 4 × digital input incl. counter
- 4 × digital output
- 1 × analog input
- 1 × analog output

Software

- Powered by OS Linux
- Mervis – IDE (IEC 61131-3), HMI editor, proxy server, cloud database, SCADA, wide range of supported protocols
- Open-source solutions – Node-RED, openHAB, Homebridge, FHEM, PiDome, DomotiGa, Domoticz, Pimatic and many more
- Custom SW implementation– EVOK open API, Modbus TCP interface, SysFS

## FUNCTIONALITY

Automation, IoT and IIoT, remote online monitoring and regulation, HVAC control, SCADA, sensorics, smart home control (lighting, doors, locks, irrigation etc.)

Communication interfaces

- 2 × RS485
- 1 × RS232
- 1 × 1-Wire bus
- 1 × 1Gbit Ethernet
- 1 × 10/100Mbit Ethernet
- 2 × USB 2.0

Other features

- Built-in webserver
- Special functions – Direct Switch, MasterWatchdog, user LEDs
- Durable aluminium chassis (IP20)
- Extended operating temperature range
- Available in an OEM variant
- Custom development available (IQRf, LoRa, wM-Bus, ZigBee, EnOcean and more)

# Unipi Axon S155

## • Communication

Ethernet	1 × 1Gbit Ethernet 1 × 10/100Mbit Ethernet
Serial/bus channels	2 × RS485, 1 × RS232, 1 × 1-Wire
RS485 1 transmission speed	134 baud .. 115 200 baud
RS485 3 transmission speed	50 baud .. 3 Mbaud
RS485 galvanic isolation	Yes
RS485 biasing resistors	Yes, 560 Ω
RS485 terminating resistor	Built-in attachable, 120 Ω
RS232 transmission speed	50 baud .. 3 Mbaud
RS232 galvanic isolation	No
1-Wire galvanic isolation	Yes
1-Wire output voltage Vcc	5 V
1-Wire max. current Vcc	50 mA
1-Wire connector	3 × pole, max. 1.5 mm <sup>2</sup>
WiFi	IEEE 802.11 b/g/n
Bluetooth	4.0, Low Energy (BLE)
WiFi/Bluetooth antenna	Internal
USB	2 × USB 2.0

## • Digital inputs

Nr.of inputs × groups	4 × 1
Common connector	DIGND
Galvanic isolation	Yes
Functions of inputs	Counter (incl. memory), signalization, Direct Switch
Max. frequency of counter input signal	10 kHz
Input voltage of log. 0	Max. 3 V DC
Input voltage of log. 1	Min. 7 V DC
Max. input voltage	35 V DC
Input resistance	6 200 Ω
Delay 0→1/1→0	20 μs / 60 μs

## • Digital outputs

Nr.of outputs × groups	4 × 1
Common connector	DOGND
Galvanic isolation	No
Type of output	NPN transistor (open collector)
Optional functions	PWM
Switchable voltage	5-50 V DC
Switchable current continual/pulse	750 mA / 1 A
Max. total current DO1 – DO4	1 A
PWM max. frequency	200 kHz
PWM max. resolution	16 bits

## • Analog inputs

Nr.of inputs × groups	1 × 1
Common connector	AGND
Available functions	0-10 V 0-20 mA
Galvanic isolation	No
Resolution	12 bits
Conversion speed	10 μs
Input resistance	66 kΩ – U 100 Ω – I
Resistance measurement method	–

## • Analog outputs

Nr.of outputs × groups	1 × 1
Common connector	AGND
Available functions	AO 0-10 V / 0-20mA Resistance measurement: 0-2 kΩ (Pt/Ni1000)
Galvanic isolation	No
Max. voltage/current	10 V / 20 mA
Resolution	12 bits
Conversion speed	1 ms
Resistance measurement method	2wire

## • Power supply

Rated voltage - SELV	24 V DC
Power consumption	Typ. 3 W Max. 12 W
Reverse polarity protection	Yes

## • Installation and operating conditions

Operating conditions	0 °C .. + 70 °C, relative humidity 10 % .. 95 %, without aggressive substances, condensing vapor and fog
Storing conditions	- 25 °C .. + 70 °C, relative humidity 10 % .. 95 %, without aggressive substances, condensing vapor and fog
Degree of protection IP (IEC 529)	IP 20
Operation position	Horizontal
Installation	On 35mm DIN rail into distribution box (holder included)
Connection	Pluggable terminal blocks
Wire gauge	Max. 2.5 mm <sup>2</sup>

## • Dimensions and weight

Dimensions	70 × 90 × 60 mm
Weight	210 g

## • Standards compliance

EN 60730-1 ed.3:2012
RoHS
WEEE