

Unipi Neuron S103-G

PRODUCT DESCRIPTION

Unipi Neuron S103-G is a programmable logic controller designed for automation, control, regulation and monitoring. The S103-G's universal architecture includes digital and analog I/Os, making it suitable for simple installations. As a special feature, the S103-G also features an integrated GSM/GPRS functionality for internet access or sending/receiving SMS messages. The controller is also provided with a single RS485 serial interface and a 1-Wire interface for connection of digital humidity or temperature sensors.

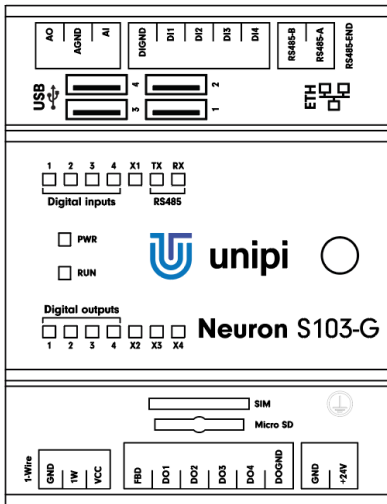

COMPUTING MODULE

Raspberry Pi 3 Model B
(quad-core 1.2 GHz CPU, 1 GB RAM)

FEATURES

Inputs/outputs

- 4 × digital input incl. counter
- 4 × digital output
- 1 × analog input
- 1 × analog output

Software

- Powered by OS Linux
- Mervis – IDE (IEC 61131-3), HMI editor, proxy server, cloud database, SCADA, a wide range of supported protocols
- Commercial solutions– CODESYS, REXYGEN
- Open-source solutions – Node-RED, openHAB, Homebridge, FHEM, PiDome, DomotiGa, Domoticz, Pimatic and many others
- Custom SW implementation – EVOK open API, Modbus TCP interface, SysFS

FUNCTIONALITY

Smart home control (lighting, doors, smart locks, irrigation etc.), automation, remote online supervision, monitoring and regulation, HVAC control, SCADA, sensors, IoT/IIoT

Communication interfaces

- 1 × RS485
- 1 × 1-Wire bus
- 1 × 10/100Mbit Ethernet
- 4 × USB 2.0
- 1 × GSM/GPRS interface

Other features

- Built-in webserver
- Special functions – Direct Switch, MasterWatchdog, user LEDs
- Durable aluminium chassis (IP20)
- Available in an OEM variant
- Custom development available (IQRf, LoRa, wM-Bus, ZigBee, EnOcean and more)

Unipi Neuron S103-G

• Communication

Ethernet	1 × 10/100 Mbit Ethernet
Serial/bus channels	1 × RS485, 1 × 1-Wire
RS485 transmission speed	134 baud .. 115 200 baud
RS485 galvanic isolation	Yes
RS485 biasing resistors	Yes, 560 Ω
RS485 terminating resistor	Built-in attachable, 120 Ω
1-Wire galvanic isolation	Yes
1-Wire output voltage Vcc	5 V
1-Wire max. current Vcc	50 mA
1-Wire connector	3 × pole, max. 1.5 mm ²
WiFi	IEEE 802.11b/g/n
Bluetooth	4.2, Low Energy (BLE)
WiFi/Bluetooth antenna	Internal
USB	4 × USB 2.0
GSM/GPRS class	10
GSM frequency bands	850/900/1800/1900 MHz
SIM card type	miniSIM
GSM/GPRS antenna	2 dBi - SMA

• Digital inputs

Nr. of inputs × groups	4 × 1
Common connector	DIGND
Galvanic isolation	Yes
Functions of inputs	Counter (w/o memory), signalization, Direct Switch
Max. frequency of counter input signal	10 kHz
Input voltage of log. 0	Max. 3 V DC
Input voltage of log. 1	Min. 7 V DC
Max. input voltage	35 V DC
Input resistance	6 200 Ω
Delay 0→1/1→0	20 μs / 60 μs

• Digital outputs

Nr. of outputs × groups	4 × 1
Common connector	DOGND
Galvanic isolation	No
Type of output	NPN transistor (open collector)
Optional functions	PWM
Switchable voltage	5–50 V DC
Switchable current continual/pulse	750 mA / 1 A
Max. total current DO1 – DO4	1 A
PWM max. frequency	200 kHz
PWM max. resolution	16 bits

• Analog inputs

Nr. of inputs × groups	1 × 1
Common connector	AGND
Available functions	0–10 V 0–20 mA
Galvanic isolation	No
Resolution	12 bits
Conversion speed	10 μs
Input resistance	66 kΩ – U 100 Ω – I
Resistance measurement method	–

• Analog outputs

Nr. of outputs × groups	1 × 1
Common connector	AGND
Available functions	AO 0–10 V / 0–20 mA Resistance measurement: 0–2 kΩ Pt/Ni1000)
Galvanic isolation	No
Max. voltage/current	10 V / 20 mA
Resolution	12 bits
Conversion speed	1 ms
Resistance measurement method	2wire

• Power supply

Rated voltage - SELV	24 V DC
Power consumption	Typ. 8 W Max. 17 W
Reverse polarity protection	Yes

• Installation and operating conditions

Operating conditions	0 °C .. + 55 °C, relative humidity 10 % .. 95 %, without aggressive substances, condensing vapour and fog
Storing conditions	- 25 °C .. + 70 °C, relative humidity 10 % .. 95 %, without aggressive substances, condensing vapour and fog
Degree of protection IP (IEC 529)	IP 20
Operation position	Horizontal
Installation	On 35mm DIN rail into distribution box (holder included)
Connection	Pluggable terminal blocks
Wire gauge	Max. 2.5 mm ²

• Dimensions and weight

Dimensions	70 × 90 × 60 mm
Weight	210 g

• Standards compliance

IEC 60950-1: 2005(ed.2)
EN 62311: 2008
EN 60730-1 ed.3:2012
EN 301 489-1
EN 301 487-17 Ver. 3.1.1
EN 300 328 Ver 2.1.1
EN 301 893 V2.1.1
RoHS
WEEE