

UniPi 1.1

Technical Documentation



Contents

Overview.....	2
Description	3
GPIO port map.....	4
Power Requirements.....	5
Connecting Raspberry Pi to UniPi.....	5
Building blocks.....	5
Relays.....	5
Digital Inputs	5
5-12V Step-up (internal 12V power supply).....	6
Jumper settings	6
Analog Inputs.....	6
EEPROM.....	7
Analog Output	7
1Wire sensors.....	8
UART	8
I ² C ports	9
Technical parameters	10
Onboard I ² C ICs.....	10
Relays.....	10
Digital Inputs	10
Analog Output	10
Power Requirements.....	10
Dimensions.....	10
Revision History.....	11
Changes	11

Overview

UniPi is an add-on board for the Raspberry Pi (RPI). It features many components such as 12 (+2) digital inputs with LED signalization, two 0-10V analog inputs, one 0-10V analog output, changeover relays, single channel 1wire master controller and a real-time clock module.

The two digital inputs 13,14 and the I2C_0 bus are meant to connect via the P5 header of RPi B (only) which is no longer available on newer Raspberry Pis (B+ and newer).

We provide basic open-source Python library for interfacing the UniPi available on [GitHub](#) which is recommended to use.

There are also many platforms and libraries that are compatible with UniPi:

- [REX](#) – Industrial PLC automation tool
- [FHEM](#) – Home automation GNU/GPL v.2 Perl server
- [Wyliodrin](#) – Online visual programming service
- [HomeSeer](#) – Another home automation system
- Others... See www.unipi.technology

UniPi is fully compatible with the following Raspberry Pi models

- Raspberry Pi Model B+
- Raspberry Pi 2 Model B
- [Raspberry Pi 3 Model B](#)
- Raspberry Pi 3 Model B
- [Raspberry Pi 4 Model B](#)

UniPi mounting holes are also compatible with BeagleBone Black (technical support not provided).

Description

Major building blocks of UniPi:

- **Relays:** 8 relays 250VAC@5A or 24VDC@5A – control switching elements
- **UART port:** Standard serial port to connect serial console or many other devices (NFC readers, ...)
- **1Wire port:** Provides 1Wire bus interface to connect 1Wire devices such as temperature and humidity sensors
- **I2C port:** For connecting other extension modules for example relay or analog output modules
- **I2C configuration pins:** To connect the I2C_0 bus from the RPi (only for advanced users)
- **RTC (Real Time Clock) module:** Provides real time in case of internet or power outage (backup battery not included in the package).
- **Power 5V:** 2.1mm connector for power supply
- **RPI connector:** 26-pin connector for Raspberry Pi
- **Digital inputs:** 12(+2) galvanically isolated digital inputs for reading signals from external devices
- **12V out:** Power supply 12V@200mA - only for use with digital inputs of the UniPi
- **Configurable ports:** To configure digital inputs for use with external power source
- **Analog in:** Two 0-10V analog inputs for reading analog signals from external devices
- **Analog out:** One 0-10V analog output for proportional controlling
- **AO trimmer:** For precise adjustment of the analog output

Figure 1 - The UniPi

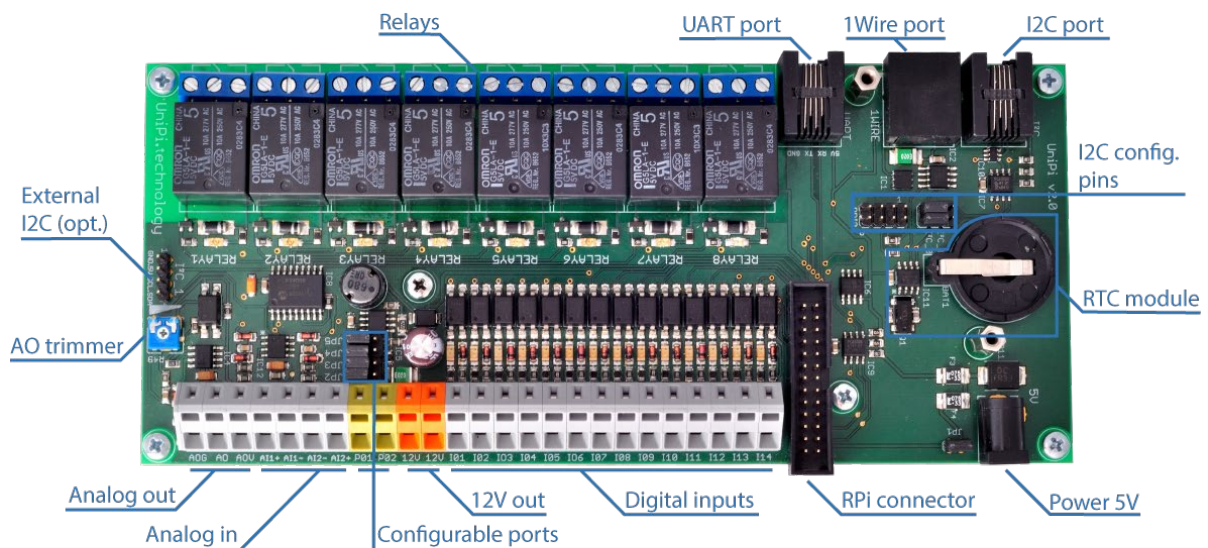

GPIO port map

Table 1 – Raspberry Pi P1 header map

UniPi	RPi BCM	Function	Description
AO	GPIO18	PWM	Analog Output 0-10V
I01	GPIO04	Digital Input	Digital Input
I02	GPIO17	Digital Input	Digital Input
I03	GPIO27	Digital Input	Digital Input
I04	GPIO23	Digital Input	Digital Input
I05	GPIO22	Digital Input	Digital Input
I06	GPIO24	Digital Input	Digital Input
I07	GPIO11	Digital Input	Digital Input
I08	GPIO07	Digital Input	Digital Input
I09	GPIO08	Digital Input	Digital Input
I10	GPIO09	Digital Input	Digital Input
I11	GPIO25	Digital Input	Digital Input
I12	GPIO10	Digital Input	Digital Input
I2C1_SCL	GPIO02	I2C1_SCL	Internal I ² C_1, RJ11 connector
I2C1_SDA	GPIO03	I2C1_SDA	
UART RX	GPIO15	UART0_RXD	UART RJ11 connector
UART TX	GPIO14	UART0_TXD	

Table 2 – Raspberry Pi P5 header map

UniPi	RPi BCM	Function	Description
I13	GPIO31	Digital Input	Digital Input
I14	GPIO30	Digital Input	Digital Input
I2C0_SCL	GPIO29	I2C0_SCL	External I2C_1
I2C0_SDA	GPIO28	I2C0_SDA	

Table 3 – MCP23008 pin map

Relay	MCP23008
8	GP0
7	GP1
6	GP2
5	GP3
4	GP4
3	GP5
2	GP6
1	GP7

Power Requirements

There are two options of powering the UniPi board and Raspberry Pi:

- **Single power source** (RPi and UniPi are powered from the same power source)
 - jumper JP1 mounted
 - 5V DC 2A through the UniPi power connector (1.5A for UniPi + RPi requirements)
 - Please note that UniPi can only provide 750mA to the RPi (max 1.1A in newest versions of UniPi)
 - Raspberry Pi micro USB power connector not used
- **Dual power source** (separate power source for each UniPi and Raspberry Pi)
 - jumper JP1 dismounted
 - Raspberry Pi powered from the micro USB port according to the RPi requirements
 - 5V DC 1.5A through the UniPi power connector

Attention:

- Powering the UniPi from the Raspberry Pi is not recommended and could damage the Raspberry Pi.
- When using the Raspberry Pi in heavy load and multiple peripherals connected we recommend dual power source solution.

Connecting Raspberry Pi to UniPi

Before the first use plug in a CR2032 battery to the battery holder.

Connecting UniPi to Raspberry Pi is straight forward:

1. Make sure you have properly configured the power jumper – see [powering requirements](#)
2. Screw the spacers to the mounting holes of the UniPi
3. Connect the provided flat cable to the RPi connector
4. Screw the Raspberry Pi to the UniPi
5. Connect the other end of the flat cable to the RPi (make sure it is not twisted)
6. Plug in the power supply

Building blocks

Relays

Maximum relay switching power is limited to 250V AC/5A or 24V DC/5A, voltages over this limit must be switched using external relay or contactor.

Relays are controller by the MCP23008 (address 0x20), see map of MCP's GPIO to relays in Table 3 . Each relay has a LED indicating its state.

There are three contacts for each relay named CO (change-over or C=connected), NO (normally opened), NC (normally closed). By default contacts CO and NC are connected (NO is not connected), by switching the relay on, CO gets connected to NO (NC is disconnected).

Digital Inputs

These inputs can be triggered by 5-24V DC voltage with minimum pulse length of 5ms. For easy visual reading of their states all inputs are equipped with LED.

When using the GPIOs make sure to set a software pull-up resistor on each GPIO to make it work properly otherwise state of the GPIO cannot be read properly.

5-12V Step-up (internal 12V power supply)

All inputs are primarily set to be driven by the internal 12V power supply. The 12V line is wired out via the orange connector marked as 12V. Do not exceed 200ma current draw.

Jumper settings

In case of using external power source, inputs must be configured by JP2 - JP5 jumpers. The configuration must be done before powering up the UniPi. Using the external power supply and proper jumper configuration provides galvanic isolation for its inputs.

Jumper configuration when using external power source:

- JP2
 - Switching this jumper to the side of the JP2 label causes the P02 (green connector) to act as an input for ground from the external power source. Otherwise P02 is connected to the internal 12V.
 - This step must be done as first when changing jumper settings.
 - Please note that after this step, the GND of UniPi is connected to P02! Make sure to proceed with JP3 settings after this step.
- JP3
 - When switched to the side of the JP3 label, inputs I01 and I02 act as inputs for signal from the connected peripheral device via the external power source.
 - The ground of power supply for this inputs must be connected to the P02.
 - Please note that to set I01 and I02 for ext. power source make sure to switch JP2 first and then JP3, after that you can safely connect the peripheral device.
- JP4
 - When switched to the side of the JP4 label, inputs I03 and I04 act as inputs for signal from the connected peripherals via the external power source.
 - The ground of power supply for this inputs must be connected to P01.
- JP5
 - When switched to the side of the JP5 label, inputs I05 - I14 act as inputs for signal from the connected peripherals via the external power source.
 - The ground of power supply for this inputs must be connected to P01.
 - Please note that I13 and I14 are wired out via the P5 header of Raspberry Pi (models before the PLUS versions).

Analog Inputs

UniPi features two analog 0-10V input channels (via the MCP3422, address 0x68) marked as AI1 and AI2. Each channel has its own + and – (e.g. AI1+ and AI1-). The + connector expects positive voltage from the connected device and – expects the negative pole (the GND). The guaranteed accuracy is 5% however 1% is commonly reachable.

To correctly calculate the input voltage, a coefficient of the resistor divider has to be taken into account. The coefficient of each channel is saved in EEPROM as single precision binary floating point format binary32 (IEEE 754). Before version 1.1 the coefficient is not saved in the EEPROM and thus must be calculated during conversion in software (Typically the value is around 5.56). See chapter EEPROM for more details. ¹

EEPROM

UniPi features onboard EEPROM (24C02) for storing important information with 2k bit memory organized into single block of 256 * 8-bit. We reserve address space 0xe0 – 0xff the rest is left for user space. The rest of unused reserved bytes are nulled.¹

Table 4 - memory organization

Starting address	Number of bytes	Example	Description
0xe0	2	fa-55	UniPi identification
0xe2	2	1.1	UniPi version
0xf0	4	0x40b089c5 (5.516818)	AI1 coefficient
0xf4	4	0x40b08b44 (5.517)	AI2 coefficient

Analog Output

Analog output is driven by the GPIO 18 PWM signal and is designed to run at 400Hz. The GPIO port is galvanically isolated from the rest of the output. The maximum current driven from this output is 20mA. This output is meant to control 3rd party devices that can adjust its power according to the 0-10V. The precision of AO in UniPi v1.0 is +-5% but also depends of the Raspberry Pi CPU usage.

External voltage must be connected to the AOV connector with maximum voltage of 35V DC.

Make sure to adjust output voltage using the blue trimmer (labeled as R49) before connecting devices to avoid causing damage.

Behavior of the AO has changed since the UniPi version 1.1 (incl.). Before that 100% duty cycle on PWM meant to output 0V, and 0% DC (or permanent low) meant 10V. But after the version 1.1 (including v 1.1) the process is different and more logic meaning 100% duty cycle is 10V and 0% is 0V.

¹

1Wire sensors

UniPi features single channel 1Wire master controller (DS2482-100, address 0x18). The 1Wire bus is wired out via the RJ45 connector (see Table 5 for detailed description). The data line is ESD protected and the 5V power current is limited to 200mA.

Table 5 - 1Wire RJ45 connector

RJ11 pin	Function
1	-
2	-
3	-
4	-
5	5V
6	DATA
7	DATA
8	GND

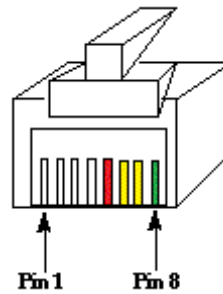

UART

The UART interface of Raspberry Pi is wired out via the RJ11 connector labeled UART. See Table 6 - UART RJ11 connector. This port does not have any protection, so make sure to be careful when connecting devices. Operating voltage of this port is 3V3.

Table 6 - UART RJ11 connector

RJ11 pin	Function
1	-
2	5V
3	RX
4	TX
5	GND
6	-

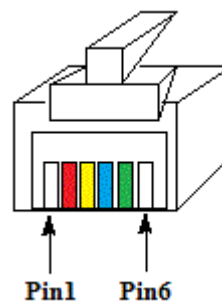

I²C ports

Raspberry Pi has two I²C interfaces. The I²C_1 of the RPi is connected via the main P1 connector and does not need any special modification. All the onboard ICs are connected to this bus. The second I²C bus, I²C_0, is wired out via the P5 connector which needs to be soldered from the bottom of the Raspberry Pi. Please check our online tutorial for further information.

The I²C_1 is by default wired out via the onboard RJ11 connector labeled I²C and features ESD protection. UniPi also features optional I2C port (labeled I²C_1) on the edge of the board but does not have any connector by default.

Please note that the I²C_0 has been reserved for special purpose starting with RPi models + and thus is no longer recommended to use.¹

Table 7 - I²C RJ11 connector

RJ11 pin	Function
1	-
2	5V
3	I2C data (SDA)
4	I2C clock (SCL)
5	GND
6	-

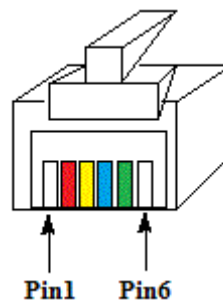

Technical parameters

Onboard I²C ICs

All onboard I²C chips are connected to the main bus.

Table 8 - I2C chip addresses

Chip type	Address	Usage
MCP23008	0x20	Relays
DS2482-100	0x18	1Wire master
MCP79410	0x6F, 0x57	Real Time Clock
MCP3422	0x68	ADC
24AA00/24C02	0x50-0x57	EEPROM

Relays

- Version 1.0: 8x Omron G5LA-1-E: 250V AC/5A or 24V DC/5A
- Version 1.1: 8x Finder 36.11.9.005.4001

Digital Inputs

- 12(+2)x 5-24V DC

Analog Output

- Maximum supply voltage: 35V
- Maximum output current: 20mA

Power Requirements

- The main UniPi power connector is standard 2.1mm inner diameter, 5.5mm outer diameter
- 5V DC 2A in single power supply mode (JP1 connected)
 - Attention: UniPi can supply only 750mA (1.1A in newest version) to the RPi
- When JP1 disconnected
 - 5V DC 1.5A for UniPi
 - 5V DC min 1A for Raspberry Pi (according to the RPi manual)

Dimensions

Width: 198mm

Height: 86mm

Depth: 16mm (without the RPi, cable and spacers)

Weight: 0.21kg

Revision History

Revision	Release date	Author
1.0	6. 11. 2014	Tomas Hora
1.1	4. 3. 2015	Tomas Hora & Imas NV

Changes

- ¹ Introduced in version 1.1



Thanks to Imas NV, Turnhout, Belgium for correction.

Raspberry Pi is a trademark of the Raspberry Pi Foundation.